

Generating a caBIG Patient Study Calendar from a Study Design in ODM with Study Design Model Extension

By Jozef Aerts

Abstract

The Study Design Model (SDM) extension for ODM is currently being developed by a working group consisting of members of the XML Technologies Team and of the Protocol Representation Group (PRG). The major features of this extension are being presented. The SDM-XML extension has been used to generate an example study design instance which has then been transformed to a caBIG Patient Study Calendar (PSC).

The SDM-XML extension

The Study Design Model extension for ODM (SDM-XML) is an extension aiming to describe study design features that were not covered by the ODM standard yet. The extension is based on the Protocol Representation Model Version 1.0 (1), but uses existing ODM 1.3.1 mechanisms and elements as much as possible (2). The extension has been defined in such a way that SDTM Trial Design domain datasets can be generated from an SDM-XML instance in an easy way.

The extension contains four major parts:

- general study information: Protocol Summary, Protocol Parameters and Inclusion/Exclusion Criteria
- structural elements: description of Arms, Epochs, Cells, Segments and Activities
- workflow: entry- and exit criteria for structural elements, transitions between activities, branching
- timings: timings and timings windows for activities and for transitions between activities: absolute and relative timing constraints.

All SDM-XML elements live in a separate XML-namespace, but can reference existing ODM elements or can be referenced by extension elements of existing ODM elements. For example, SDM “entry and exit criteria” elements reference classic ODM “ConditionDef” elements to allow for machine-readable conditions. Such machine-readable entry- and exit criteria can then be loaded into hospital information systems to search for eligible candidate subjects.

Classic ODM “StudyEventDef” elements may also reference SDM “Activity” elements, allowing to include activities in visits that are not data collection activities, such as administration of study drug.

Although the SDM-XML extension is still in development, it is already being extensively tested for implementability and integrability by technology vendors that have an active volunteer in the development team. This means that once the extension becomes a final standard, software tools will quickly become available for setting up complete study designs using the extension.

Fig. 1 shows an XML-snippet of a set of inclusion and exclusion criteria definitions, referencing classic ODM ConditionDef elements which allows to describe the criterium in a machine-readable language.

```

- <sdm:InclusionExclusionCriteria>
+ <Description>
- <sdm:InclusionCriteria>
  <sdm:Criterion OID="CRIT.MIN_AGE" Name="Inclusion criterion for age" ConditionOID="COND.MIN_AGE" />
  <sdm:Criterion OID="CRIT.ALZHEIMER_DISEASE" Name="Inclusion criterion: subject has AD"
    ConditionOID="COND.ALZHEIMER_DISEASE" />
  <sdm:Criterion OID="CRIT.MMSE_10-23" Name="Inclusion criterion: MMSE between 10 and 23"
    ConditionOID="COND.MMSE_10-23" />
  <sdm:Criterion OID="CRIT.HACHINSKI" Name="Inclusion criterion: Hachinski score <= 4"
    ConditionOID="COND.HACHINSKI" />
  <sdm:Criterion OID="CRIT.CNS_1_YEAR" Name="Inclusion criterion: CNS in past year compatibe with AD"
    ConditionOID="COND.CNS_1_YEAR" />
</sdm:InclusionCriteria>
- <sdm:ExclusionCriteria>
  <sdm:Criterion OID="CRIT.MAX_AGE" Name="Exclusion criterion for age" ConditionOID="COND.MAX_AGE" />
</sdm:ExclusionCriteria>
</sdm:InclusionExclusionCriteria>

```

Fig. 1: XML-snippet of a set of inclusion and exclusion criteria definition, referencing classic ODM ConditionDefs

Fig. 2 shows part of the workflow for the LZTT trial from the first CDISC-FDA pilot, as generated in a prototype design tool based on the current extension.

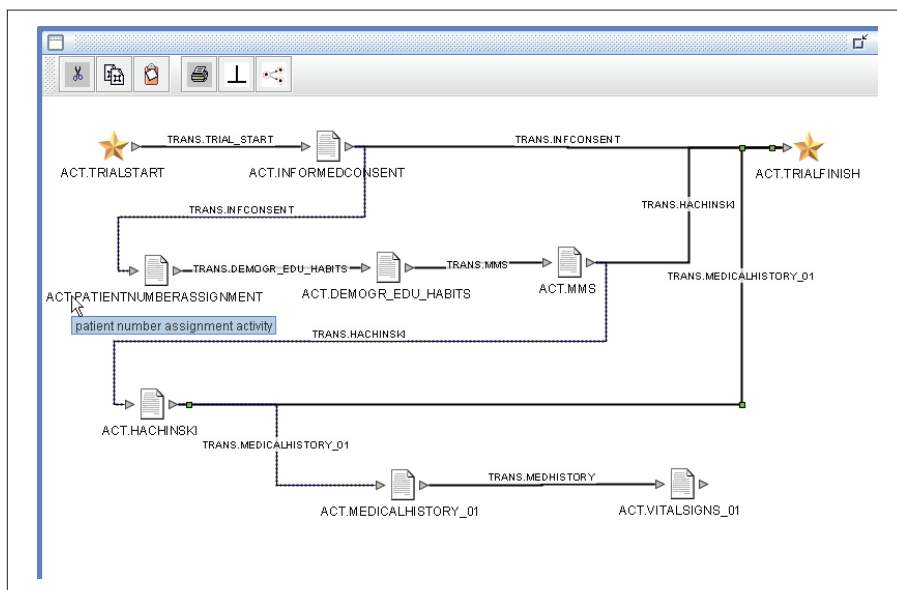

Fig. 2: Part of the workflow for the LZTT trial from the first CDISC-FDA pilot

Fig. 3 shows how timing constraints for transitions between activities can be added. In the SDM-XML they are however stored in the XML separately from the transition definition itself.

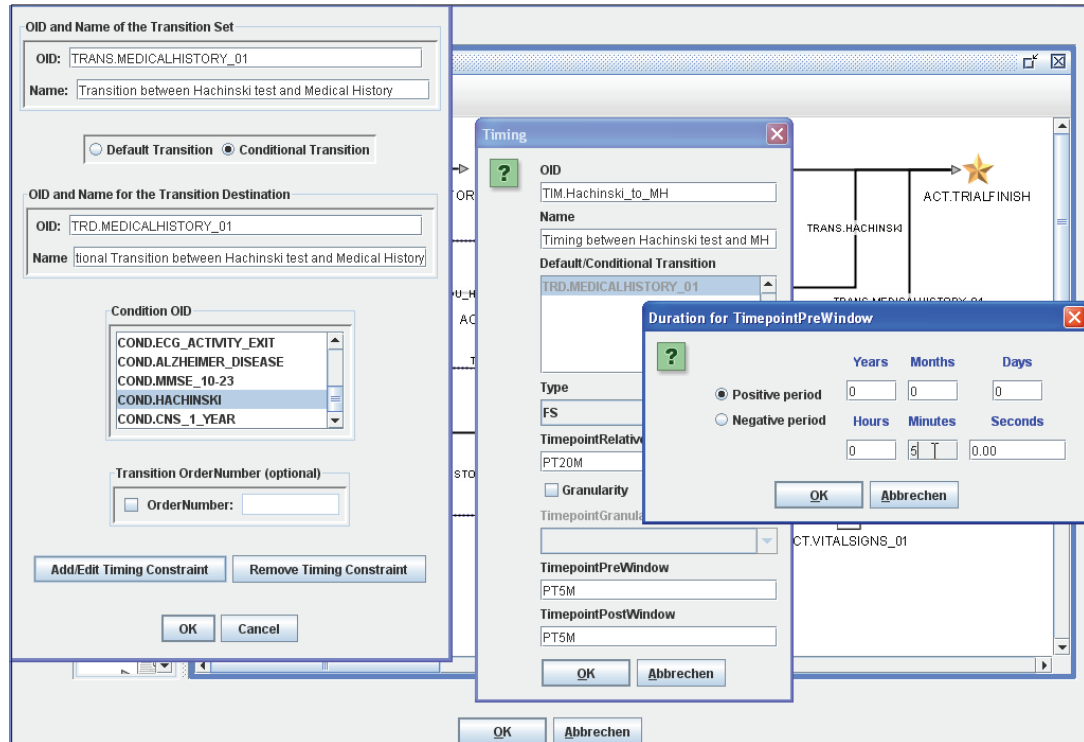

Fig. 3: Addition of timing constraints between activities in a prototype study design tool implementing SDM-XML

Transformation to caBIG Patient Study Calendar (PSC)

The PSC is an open source software tool for planning study activities developed by the National Cancer Institute (NCI) under the caBIG program (3). The web-based software has an interactive graphical user for adding activities to the calendar, but also allows to upload XML files defined in a specific format (PSC-XML).

The PSC is also based on the CDISC Protocol Representation Model Version 1.0 (PRM), and it should thus be possible to transform a CDISC ODM file containing SDM extension elements to a PSC-XML file for upload to the PSC and thus to generate a patient study calendar automatically.

When comparing the SDM-XML and the PSC however, one finds some differences in implementation of the PRM, which causes some hindrances for such a transformation:

- in PSC, segments contain one or more “periods”, whereas the concept of “period” is unknown in SDM-XML
- the “periods” in the PSC have a duration, where durations in SDM-XML can only be between activities
- in PSC, activity timings are relative to the start of a period, whereas in SDM-XML timings can only be defined between activities

- the smallest time unit in PSC is a “day” whereas any time unit can be used in SDM-XML. Also the order of activities within a day is undetermined in PSC
- PSC uses GUIDs (128 bit Globally Unique Identifiers) (4) as identifiers for the objects whereas in ODM there are no restrictions on the OIDs identifiers

These differences in implementation can however be overcome when the SDM-XML instance is constructed in such a way that (fig. 4):

- a segment is regarded as consisting of one period only in PSC.
- “Scheduling” activities are added to each segment, one for the start of the segment, and one for the end of the segment. These can then be used as anchors.
- timings are only defined with a “segment scheduling activity” as the anchor activity, so that all timings are relative to the start of their containing segment.
- the PSC segment duration is defined as being defined from a timing between the “segment start scheduling activity” and the “segment end scheduling activity”.

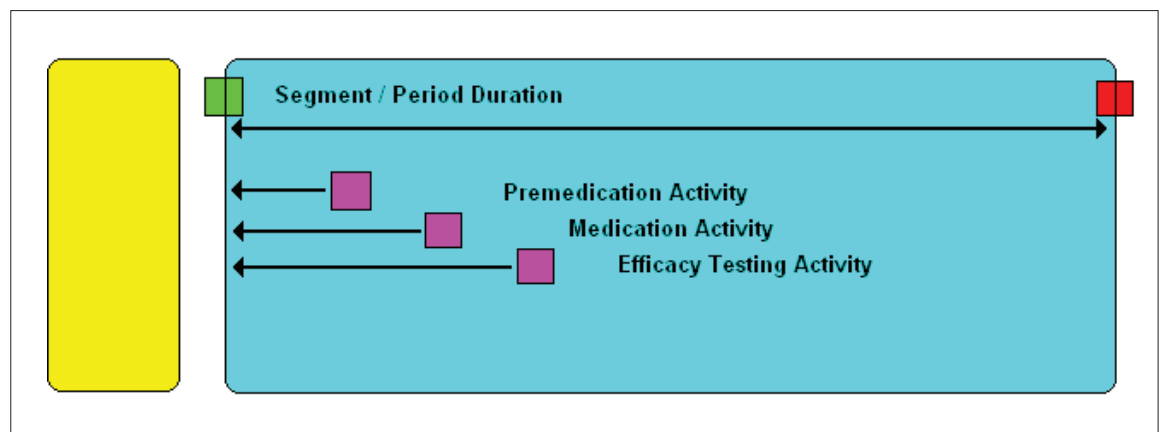

Fig. 4: Using scheduling activities at the segment start and end to define segment/period durations and activity timings relative to the start of the segment/period

We have build a prototype study design tool that implements the SDM-XML and added a feature that validates whether the study design is suitable for transformation to a PSC instance.

If it is, the user can then generate the PSC-XML (using a transformation stylesheet) from the study design. The PSC-XML can then be loaded by the PSC web application which then generates the equivalent patient study calendar.

This process is depicted in fig. 5.

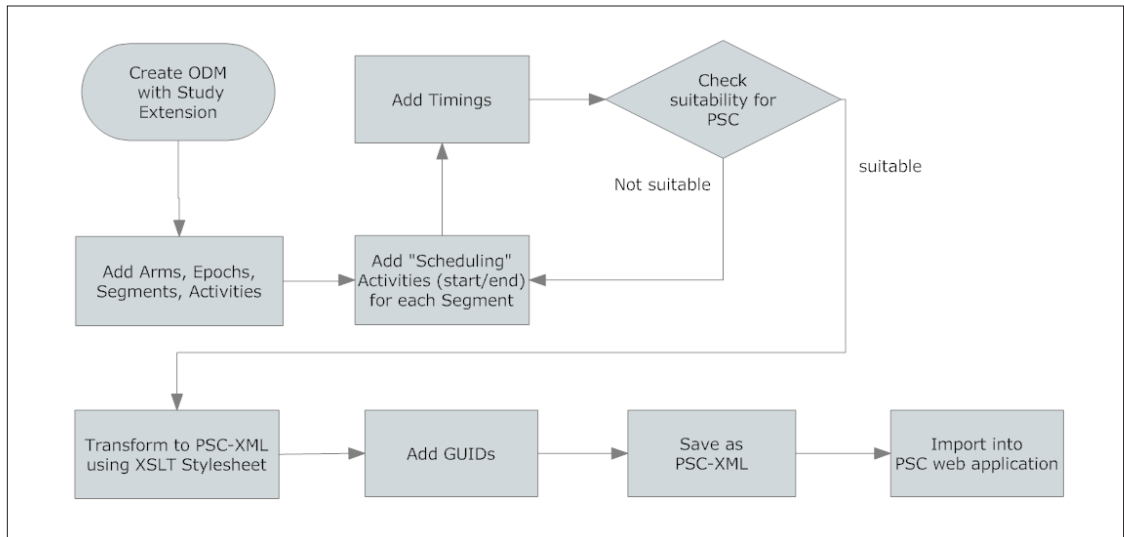

Fig. 5: Process of generating a patient study calendar from an SDM-XML instance as implemented in a prototype study design tool.

A picture of the result of such an import into the PSC web application is given in fig. 6.

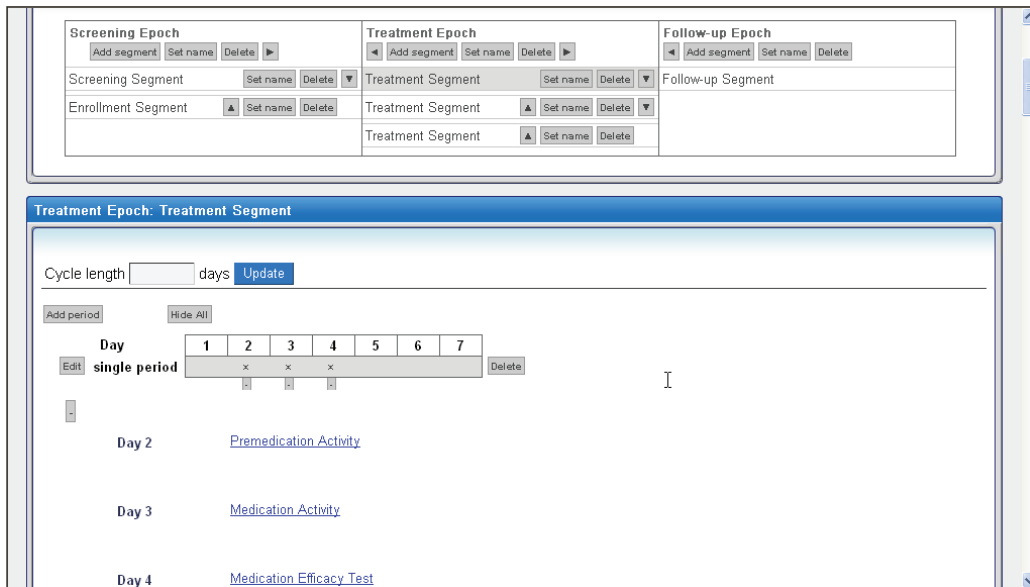

Fig. 6: Result in the Patient Study Calendar web application graphical user interface of the import of a study design generated in SDM-XML after transformation into PSC-XML.

Conclusions

The new SDM-XML extension allows to define many more features of a study design in a machine-readable form than has ever been possible before. The extension has been defined so that SDTM “Trial Design” datasets can in principle be generated automatically from an SDM-XML instance. The extension opens a new set of possibilities for interaction with hospital planning and information systems.

If scheduling activities are added for start and end of segments and used as anchors for other activities in SDM-XML, the study design can be used to generate a caBIG Patient Study Calendar automatically.

References

1. Protocol Representation Model v.1.0: <http://www.cdisc.org/protocol>
2. Operational Data Model v.1.3.1: <http://www.cdisc.org/odm>
3. Patient Study Calendar: <https://cabig.nci.nih.gov/tools/PatientStudyCalendar>
4. For more information about GUIDs, see e.g. wikipedia: http://en.wikipedia.org/wiki/Globally_unique_identifier

© Copyright CDISC October 2011 cdisc.org